



ACTIVE®

MADE IN ITALY

2024 MACHINE CATALOGUE





A special
thank you



BRUSHCUTTERS  10	LAWN MOWERS  24	SCARIFIERS  34
HEDGE TRIMMERS  38	POWER TRACK  44	FLAIL MOWERS  52
SOD CUTTERS  58	AUGERS  62	SHAKERS & HARVESTERS  68
CHAINSAWS  74	PRUNERS & TYING MACHINES  80	TILLERS  90
GENERATORS & INVERTERS  94	ENGINE  98	

Follow us on our social channels!



Contents

Active history



First ACTIVE headquarters in 1991 at the farm owned by Griffini Alberto's father

The year was 1991, and **Alberto Griffini** and his partner **Giorgio Buoli** who, thanks to their passion and determination, began this adventure in a farmhouse where they built the **first liquid-cooled engines** for 6-speed 125 Go karts (40 hp) and a twin-cylinder engine for ultralights (68 hp).

After a few years, one September day they decided together to embark on an ambitious challenge, bordering on the impossible while having to compete with giants on the market: **designing and building brushcutter engines** for which power and durability was to be the main objective.

It was on 10 January 1994 when the first technical drawing of the brushcutter designed by the two young partners took shape. At the end of June of that year, the first 52 c.c. engine was fully operational.



Extremely satisfied with their work, they then decided to call their new business "**ACTIVE**". An international term that fully reflects their professional and emotional nature.

Right from the start, ACTIVE was also able to design and manufacture many moulds in-house, which helped them be able to produce products very quickly. It also invested heavily in numerical control equipment to help control not only costs but also the precision construction of engine components, necessary for the efficiency and durability of the brushcutters that were the company's workhorse at the time.

ACTIVE developed and tested all the engines it produced in-house. An important choice considering the historical period, but a necessary choice if they wanted to be able to control and maintain the quality that still distinguishes it today without relying on external manufacturers.

ACTIVE means vitality, innovation and drive. From 1994 to present day, brushcutter engine design and manufacture has been carried out at the company's headquarters in San Giovanni in Croce in the province of Cremona, which has expanded over the years from the initial 4 employees and 1200 square metres of factory space to the current 10,000 square metres and 70 permanent employees.

Production is always subject to technological renewal. In fact, from 1996 until today, production has been controlled by numerically controlled machining centres, automatic lathes and vertical warehouses for storing individual components.

ACTIVE's in-house technical departments keep product quality under control on a daily basis thanks to numerous dimensional control instruments, while energy efficiency and fluid dynamics studies continue to be validated in the experimental test room.

Our main objective has always been to be environmentally friendly and take care of our Earth, especially that for building in Italy. Technological renewal not only plays a part in production but also in the design of new products. In fact, over the years, the range of products designed and built by ACTIVE has increased, with the addition to their catalogue of chainsaws, tracked wheelbarrows, lawn mowers, hedge trimmers and accessories. All while respecting the environment. Always.

ACTIVE collaborates with **Italian and international universities** to keep up with the times. And this is why the product catalogue has increased further recently, bringing in cordless/wireless battery technology.

The ACTIVE philosophy has always been very close to environmental protection and ecology, so much so that since 2010 the roofs of the factory has been completely covered with photovoltaic panels that, with the help of the sun, power the machinery in production.

Our headquarters

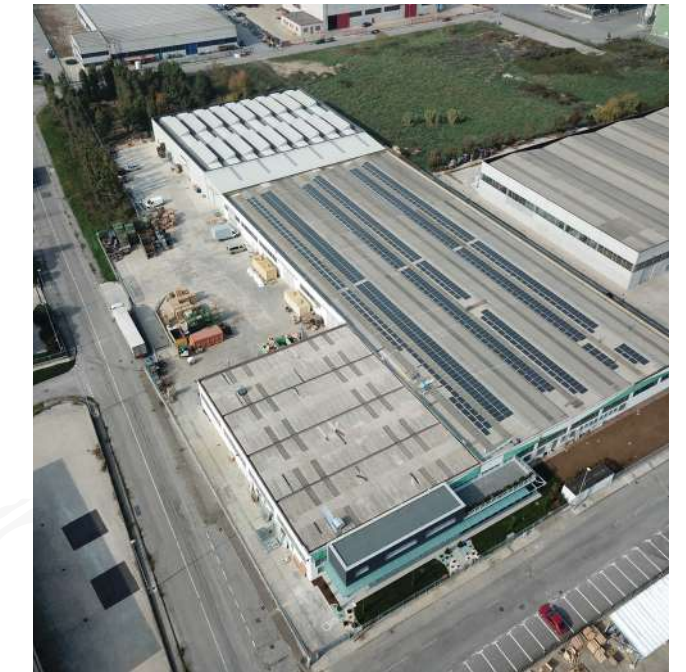

Today, ACTIVE's gaze is turned towards the future, towards an environmentally-sustainable world and, above all, towards environmentally-sustainable, quality products. Thanks to collaboration with the universities of Milan and Turin, ACTIVE has been able to rapidly develop new products with low emission endothermic engines.



Active today, 2024



Active has always been different



Part of the staff during the 30th anniversary celebrated in 2022.



The owners Buoli and Griffini.



**Proud to be
spokesman for the
MADE IN ITALY**

**More than
400 retailers
in whole Italy**



Technological development

*environmentally
sustainable*



In 2010, ACTIVE, in line with its philosophy of searching for new products and increasingly functional and environmentally-friendly technical solutions, decided to equip itself with a roof entirely covered with photovoltaic panels.

ACTIVE is now energy self-sufficient throughout the entire production process and contributes to an environmentally-sustainable form of development.

Research and Development

ACTIVE is equipped with the best CAD design systems, specific material testing programs, component durability, mechanical and thermal stress analysis, 3D printers and fluid dynamics analysis.

Thanks to collaboration with the universities of Milan and Turin, ACTIVE has achieved excellent results in the study of 2-stroke engines both in terms of reducing specific fuel consumption and in the considerable increase in specific power.

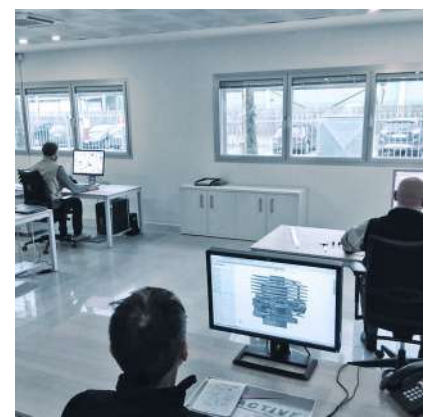

Experimentation and endurance tests

ACTIVE has equipped itself with test rooms for the study and experimentation of low emission and long-life engines. It is able to monitor the running engine in all its characteristic parameters such as temperature and pressure at every point, measuring consumption, torque, power, rpm and emissions. An airconditioned test room can be used for 1000 hours of tests carried out on its engines.

Production and Quality

The most modern CNC machine tools in the company guarantee speed and precision in machining. Constant automatic checking of measurements using 3D instruments keeps the quality of parts under control.



Assembly

ACTIVE assembles and checks all machines and each engine is tested at the end of the line.

Brushcutters

A professional and complete range to meet any need...

Weeds, brushwood and uncultivated bushes rule your gardens? No problem! For every type of terrain and for any need Active has the brushcutter that is right for you.

Brushcutters Active are easily used by both professional gardeners and simple green lovers.

Indispensable tools on difficult terrain and in areas not accessible with the lawnmower, ensure maximum efficiency.

Convenient to carry and easy to handle, our Brushcutters will meet all your needs thanks to the wide range of tools and accessories you can choose from.



VIDEOS



Brushcutters



STRATO CHARGED

BRUTALE®

The professional's future

- Very low pollutant emissions
up to 80% reduction of HC from 40,000 ppm to 8,000 ppm.
- Significant increase in torque and power (up to +30%).
- Significant reduction in fuel consumption (up to -20%).



STRATO CHARGED

Components



ENGINE CRANKCASE

Magnesium alloy crankcase to reduce weight by 30%.



CYLINDER

Aluminium alloy cylinder with STRATO-CHARGED technology.



PAPER FILTER

Paper filter increased for greater autonomy before cleaning.



THERMAL FLANGE

Special bakelite four-point thermal flange with 4 integrated steel bushings.



FLYWHEEL

Diameter 115 mm
Cooling assured!



CRANKSHAFT

Steel crankshaft cemented with new balance.



CLUTCH BELL

Diameter 78 mm
Surface ground internally.

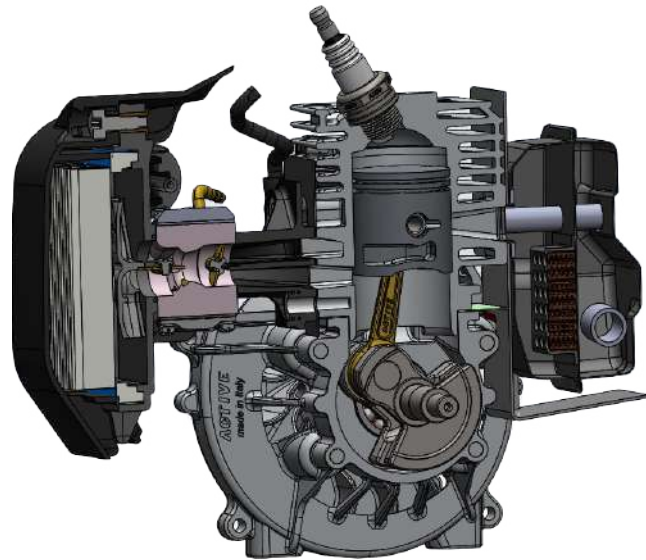

STRATO CHARGED technology

The important amount of clean air that enters from the outside through the two separate intake lights and that is accumulated in the displacement of the cylinder, favors the phases of motor washing that then take place with fresh air.

All this guarantees a drastic reduction - up to 80% - of HC (unburned hydrocarbons) outgoing.

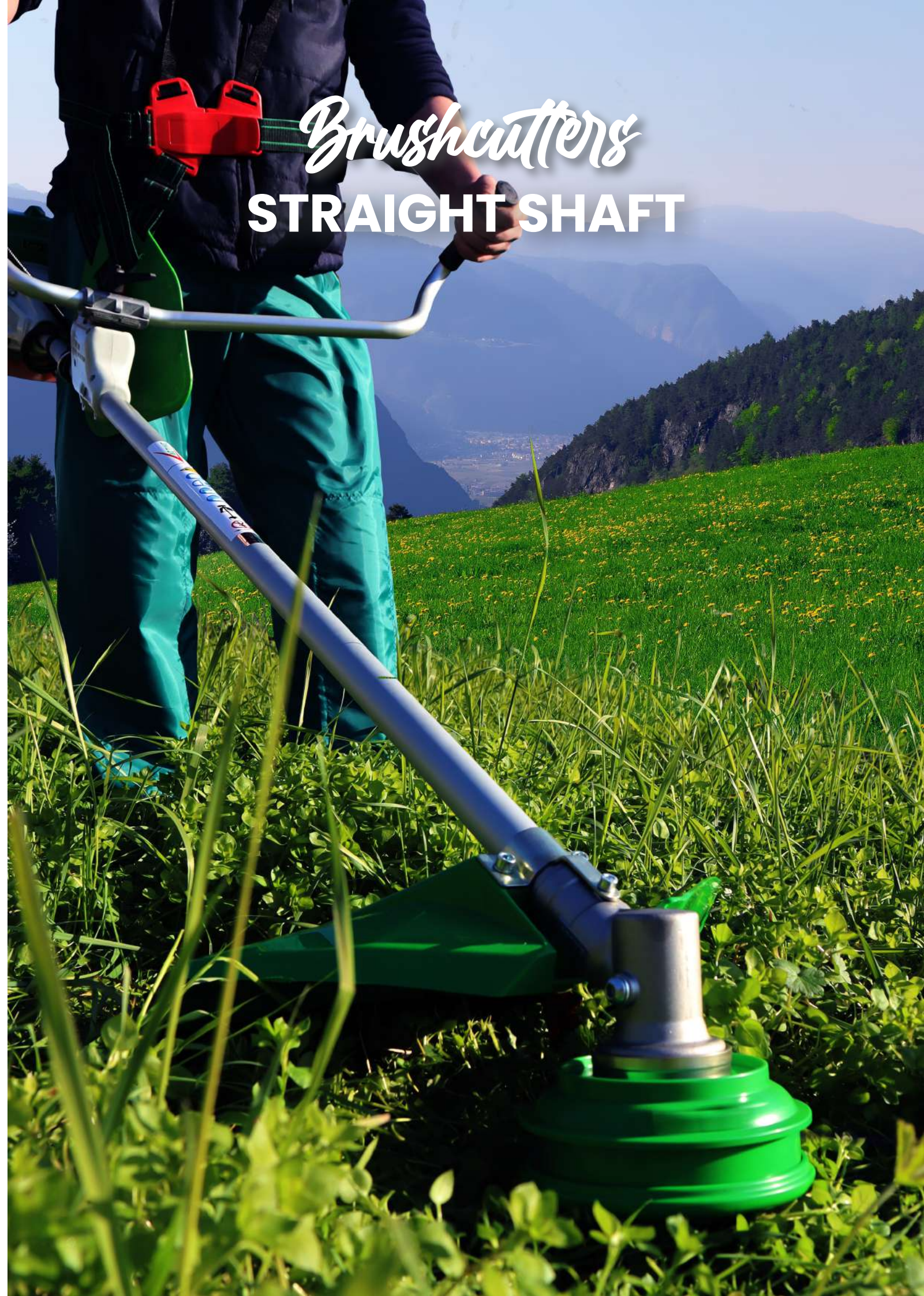

Handlebar



Model L

Ergonomic handle for perfect comfort during use.



Model B

Easy to handle handlebar that guarantees an excellent balance of the weight of the machine.



Model BT with anti-vibration system Twin Dumper System



Easy to adjust and handle, it is ergonomic to any height; the BT models have been designed with the anti-vibration system placed between the main rod and the handlebar.



Safe harness

Ergonomic and adjustable Made in Italy Cordura fabric harness which evenly distributes the weight of the brushcutter and ensures less fatigue at the end of the working day.

The Safe model is included as standard in models B and BT except for 25, ST25, 28 e ST32, 35, ST37. It is available as an accessory with the code: **020167**.

Range models **BRUTALE**

STRATO CHARGED

CODE	MODEL	DISPLACEMENT (cm ³)	POWER (Cv / kW)	Ø TRANSMISSION (mm)	Ø CLUTCH (mm)	TANK CAPACITY (L)	WEIGHT (kg)*
1660008	ST65 BT	61.5	4.5/3.3	30	78	1.1	10.0
1500004	ST50 L	50.9	3.4/2.5	30	78	1.1	9.0
1500008	ST50 BT	50.9	3.4/2.5	30	78	1.1	9.0
1370004	ST37 L	30.8	2.2/1.6	26	62	0.6	6.0
1370008	ST37 BT	30.8	2.2/1.6	26	62	0.6	6.0
1320004	ST32 L	30.8	2.2/1.6	26	62	0.6	6.0
1320002	ST32 B	30.8	2.2/1.6	26	62	0.6	6.0
1252004	ST25 L	25.4	1.7/1.25	24	54	0.6	5.3
1252002	ST25 B	25.4	1.7/1.25	24	54	0.6	5.3

*Without cutting blade and when empty

ST65



ST50



ST32
ST37



ST25



ST32 & ST37 HIGH POWER

1 HIGH-PERFORMANCE ENGINE 2 TYPES OF WORK

ST32 for the very demanding private and professional who need a high performance and ultra light machine.

ST37 equipped with conical torque HIGH POWER ideal for professional use. The perfect machine for the maintainer who wants superb performance, but at the same time handling and lightness.



Range models



Performance comparison

POWER AND TORQUE

Legend

- Power STRATO CHARGED
- Power previous model
- Pair STRATO CHARGED
- Previous model pair

The comparison between the two graphs shows that, with the same RPM, the new STRATO CHARGED engine reaches values of power and torque considerably higher than the previous model.

For this test the 2.4 engine is used as a comparison engine, as the most similar to the ST25 model in terms of displacement.

ST25 - 2.5

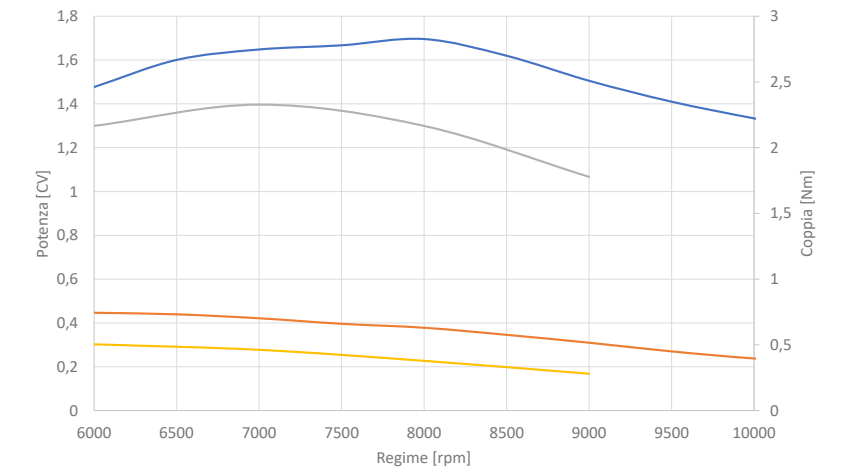

ST32 - 3.5

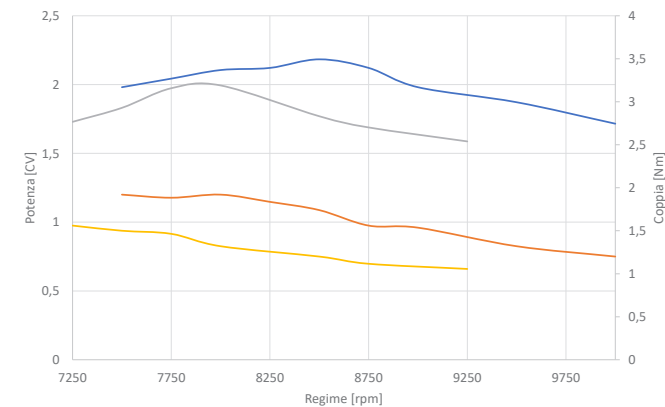

ST65 - 6.5

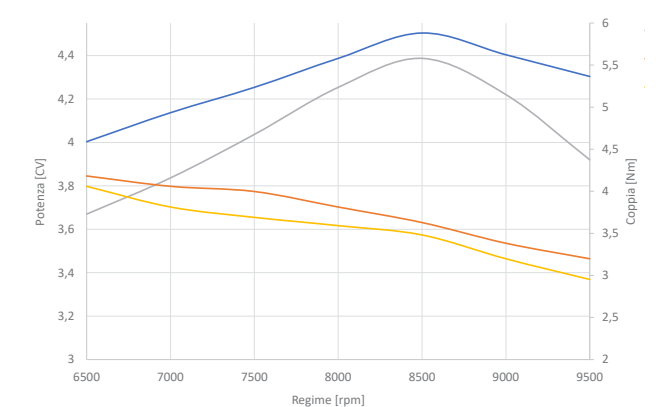

CODE	MODEL	DISPLACEMENT (cm ³)	POWER (cv / kW)	Ø TRANSMISSION (mm)	Ø CLUTCH (mm)	TANK CAPACITY (L)	WEIGHT (kg)*
1654002	6.5 BT Brutale®	62.0	4.5/3.3	30	78	1.1	8.9
1554002	5.5 BT	51.7	3.0/2.2	30	78	1.1	8.4
1550002	5.5 B	51.7	3.0/2.2	30	78	1.1	8.2
1550004	5.5 L	51.7	3.0/2.2	30	78	1.1	7.9



*Without cutting blade and when empty

Emissions

The graph shows the reduction of pollutant emissions of nitrogen oxides (Nox) and unburned hydrocarbons. (HC).

Legend

- Emissions from previous models
- Emissions from STRATO CHARGED models

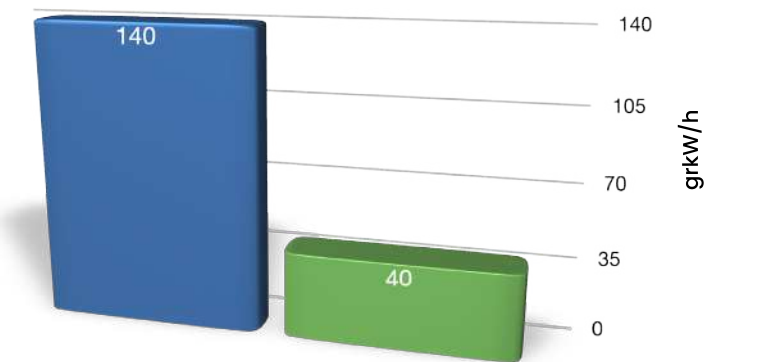

Nox + HC

Brushcutters EVOLUTION



1 engine body, 5 functions *Evolution Multifunction*

CODE	MODEL	DISPLACEMENT (cm ³)	POWER (CV / kW)	Ø TRANSMISSION (mm)	Ø CLUTCH (mm)	TANK CAPACITY (L)	WEIGHT (kg)*
132GR04	ST32 EVOLUTION solo corpo Engine Strato charged	30.8	2.2/1.6	26	62	0.6	5.1
1252010	ST25 EVOLUTION solo corpo Engine Strato charged	25.4	1.7/1.25	24	54	0.6	4.3

*Without cutting blade and when empty

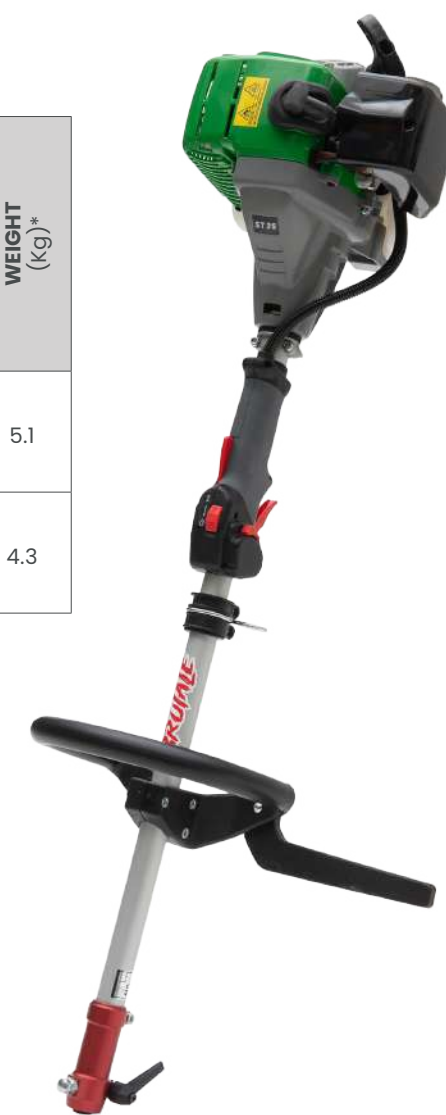

Handle a wide range of different situations with just one machine.

Turn a brushcutter into a pruner, a hoe and a hedge trimmer.

- Reliable, simple hardened steel coupling system.
- Highly robust gearbox with upper flange with three labyrinths for protection. Designed to optimally transfer power to the cutting attachment and withstand frequent shock while working.
- Tool quick fit system with a safety pin to facilitate changing of the cutting elements while however keeping them well-secured.



Discover all the available tools at PAG. 21



Gamma Evolution

CODE	MODEL	DISPLACEMENT (cm ³)	POWER (CV / kW)	Ø TRANSMISSION (mm)	Ø CLUTCH (mm)	TANK CAPACITY (L)	WEIGHT (kg)*
1545404	5.4 EVOLUTION	51.7	3.0/2.2	26	78	1.1	7.7
132EV04	ST32 EVOLUTION Strato charged	30.8	2.2/1.6	26	62	0.6	6.1
1252012	ST25 EVOLUTION Strato charged	25.4	1.7/1.25	24	54	0.6	5.3

 = Rotofix system not included

*Without cutting blade and when empty

SISTEMA ROTOFIX

Multifunctional handle in special plastic with a sweat-proof rubber sheath to increase grip. The patented Rotofix system lets operators lock the handle in a specific position or rotate it freely. This makes it possible to work with any tool in the desired position.



BACKPACK brushcutters





A convenient release pin allows the flexible shaft to be detached from the engine in seconds.



Quick attachment of the tools with safety pin that allows an easy and fast change of the cutting elements while keeping them well-secured.



Spring-loaded shock absorbers with seven coils between the engine and chassis that drastically reduce vibrations felt by the operator.



CODE	MODEL	DISPLACEMENT (cm³)	POWER (Cv / kW)	Ø TRANSMISSION (mm)	Ø CLUTCH (mm)	TANK CAPACITY (L)	WEIGHT (Kg)*
1650005	6.5 Z BRUTALE®	62.0	4.5/3.3	26	78	1.1	12
1550005	5.5 Z	51.7	3.0/2.2	26	78	1.1	11.6

*Without cutting blade and when empty



STRAIGHT PRUNER

Tube length 1050 mm

CODE	MODEL	WEIGHT (Kg)
620034	AP9025 Bar: 254 mm Chain: 1/4"	2.7
610007	Only tool	1.5



35° PRUNER

Tube length 1050 mm

CODE	MODEL	WEIGHT (Kg)
620035	AP3525 Bar: 254 mm Chain: 1/4"	2.7
610008	Only tool	2.0



HEDGE TRIMMER

Tube length 795 mm

CODE	MODEL	WEIGHT (Kg)
620040	AT550 (5 positions) Blades length: 550 mm	3.5
620840	AT480 (5 positions) ULTRALIGHT Blades length: 480 mm	3.2
600010*	Only tool 550 mm	2.5
600810*	Only tool 480 mm	2.2

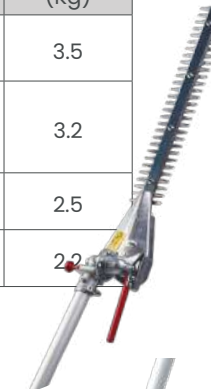

ULTRALIGHT HEDGE TRIMMER

Tube length 128 mm

CODE	MODEL	WEIGHT (Kg)
620850	AT480 (5 positions) Blades length: 480 mm	2.7



BRUSHCUTTERS

Tube length 795 mm

CODE	MODEL	WEIGHT (Kg)
620010	AD120	1.1
62HD10	AD120-HD ¹	1.1

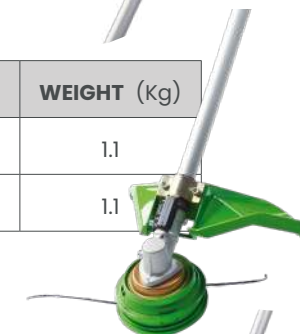

¹Heavy duty bevel gear

EXTENSIONS

CODE	MODEL	WEIGHT (Kg)
021051	E750 Length 750 mm	0.7
021404	E1500 Length 1500 mm	1.2



HOE

Tube length 795 mm

CODE	MODEL	WEIGHT (Kg)
620050	AZ150	3.1



RECIPROCATOR New

Tube length 795 mm

CODE	MODEL	WEIGHT (Kg)
620060	Ø Disc: 230 mm	2.8

Motion of the discs: alternating



Lawn mowers

The green lawn of the house...

The wide range of Active lawnmowers is able to meet the needs of all green users. Versatile, handy, compact, they differ in quality and durability. The steel and aluminium bodies of high thicknesses guarantee great reliability even in untreated soils.

Choose the most suitable cutting system to always keep the garden well cared for and make the perfect lawn.

With mulching, as well as not having to worry about collecting and disposing of the grass, you will exploit the chopped grass on the ground as valuable fertilizer.

 Cutting width

 Grass catcher capacity

 Area size

ALUMINIUM



25

STEEL



28

MULCHING



31

*Aluminium
lawn mowers*



 VIDEOS



Lawn mowers

Under the microscope

Aluminium lawn mower



SPEED REGULATOR
allows you to change the feed speed on 5400 e 5800



CUTTING HEIGHT ADJUSTMENT CENTRAL LOCKING
allows, through a lever, to adjust the cutting height on 5000 e 5400



QUICK WASH CONNECTION
galvanized steel to clean the machine at the end of the work.



Aluminium deck

55/57 cm 80 L > 2500 m² 050473 050976*

CODE	MODEL	ENGINE	TRANSMISSION	SPEED (km/h)	CUTTING HEIGHT (cm)	WEIGHT (kg)
785255	5850 SVA	ACTIVE A200	variator	2.5 - 3.8	2.0 - 8.0	50
758155	5800 SA	ACTIVE A200	single-speed	3.8*	2.0 - 8.0	48

Aluminium wheels



53/51 cm 65 L 2000 - 2500 m² 050471 050974*

CODE	MODEL	ENGINE	TRANSMISSION	SPEED (km/h)	CUTTING HEIGHT (cm)	WEIGHT (kg)
754155	5400 SA	ACTIVE A200	single-speed	3.8*	2.0 - 8.0	40
754110	5400 SH	Honda GCVx170	single-speed	3.8*	2.0 - 8.0	40
754210	5400 SVH	Honda GCVx170	variator	2.5 - 3.8	2.0 - 8.0	46

Aluminium wheels



50/48 cm 60 L 1500 - 2000 m² 050470 050976*

CODE	MODEL	ENGINE	TRANSMISSION	SPEED (km/h)	CUTTING HEIGHT (cm)	WEIGHT (kg)
750155	5000 SA	ACTIVE A166	single-speed	3.8*	2.0 - 8.0	40
750110	5000 SH	Honda GCVx170	single-speed	3.8*	2.0 - 8.0	40



Optional



Mulching Kit

The term "mulching" indicates the type of cut that allows you to chop the cut grass and redistribute it on the ground to create natural fertilizer.



Speed Reducer Kit

The speed reducer kit, including a belt and pulley, makes it possible to reduce forward speed (-1 km/h).

Steel lawn mowers



4 in 1

4 types of cutting

- Collection (with grass catcher)
- Back discharge (without grass catcher)
- Side discharge
- Mulching

Kit Mulching included!

 53/51 cm  60 L  1500 -2000 m²

 051633*

CODE	MODEL	ENGINE	TRANSMISSION	SPEED (km/h)	CUTTING HEIGHT (cm)	WEIGHT (kg)
753155	5333 SA	Active A166 OHV	monomarcia	3.5*	2.4 - 7.6	35



PLUG WITH MULCHING FUNCTION



SIDE DISCHARGE

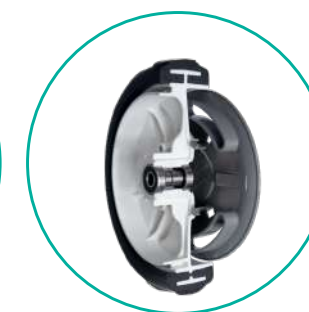

LARGE NYLON REAR WHEELS AND DOUBLE SEAL BEARINGS



ERGONOMIC HANDLE OF GRASS CATCHER

Lawn mower 5333 SA

A combination of technology and research to offer maximum versatility

Steel Deck

48/47 cm 55 L <1500 m²

051569*

CODE	MODEL	ENGINE	TRANSMISSION	SPEED (km/h)	CUTTING HEIGHT (cm)	WEIGHT (kg)
749503	4950 SH	Honda GCVx170	single-speed	3.5*	2.4 - 7.6	30
782155	4860 SA	ACTIVE A140	single-speed	3.5*	2.4 - 7.6	28
748055	4860 A	ACTIVE A140	push	-	2.4 - 7.6	27
748502	4850 A	ACTIVE A170	push	-	2.4 - 7.6	27
748530	4850 ISB	B&S 575iS Series - OHV	single-speed	3.5*	2.4 - 7.6	28

Battery

748520	4850 E	B&S 82Li Series	push	-	2.4 - 7.6	28
--------	--------	-----------------	------	---	-----------	----

43/42 cm 55 L <1500 m²

051568*

CODE	MODEL	ENGINE	TRANSMISSION	SPEED (km/h)	CUTTING HEIGHT (cm)	WEIGHT (kg)
742155	4260 SA	ACTIVE A140	single-speed	3.5*	2.4 - 7.6	27
742055	4260 A	ACTIVE A140	push	-	2.4 - 7.6	26
742503	4250 SA	ACTIVE A120	single-speed	3.5*	2.4 - 7.6	27
742502	4250 A	ACTIVE A120	push	-	2.4 - 7.6	26

Mulching lawn mowers

The term "mulching" indicates the type of cut that allows you to chop the cut grass and redistribute it on the ground to create natural fertilizer.

The advantages of this technique are many: it avoids thinning the soil and saves a large amount of fertilizer; the nutrients are released slowly in a uniform and sustainable way, encouraging a better growth of grass.



Mulching Kit included!

Easy-to-install mulching cap on the entire range.



Speed Reducer kit

The speed reducer kit, including a belt and pulley, makes it possible to reduce forward speed (-1 km/h).

Optional

Mulching lawn mower

The perfect **eco-friendly** solution that saves you time:

FUNCTIONALITY

Pulverizes the grass

grass is absorbed by the soil as fertilizer, so the lawn is more lush

CONVENIENCE

Quick cutting without any stops

- ✓ stop grass disposal
- ✓ decrease in irrigation
- ✓ reduction of fertilizers and fertilizers



Professional Engine

- Cast iron cylinder
- Double air filter: paper + sponge
- Auto choke system

55/53 cm 2000 - 2500 m²

051330

CODE	MODEL	ENGINE	TRANSMISSION	SPEED (km/h)	CUTTING HEIGHT (cm)	WEIGHT (kg)
755200	5500 SVA	ACTIVE A200	variatore	2.5 - 3.8	3.0 - 7.0	40

Under the microscope

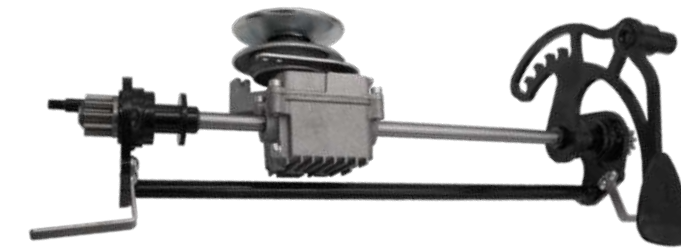

Transmission with aluminium housing



Safety cone under the deck (green)

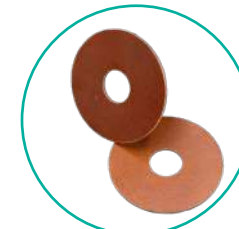

Shockproof blade clutch (purple)



All-steel blade hub (yellow)



Aluminium wheels with stainless steel clamping nut and 30 mm thick tires and double bearing

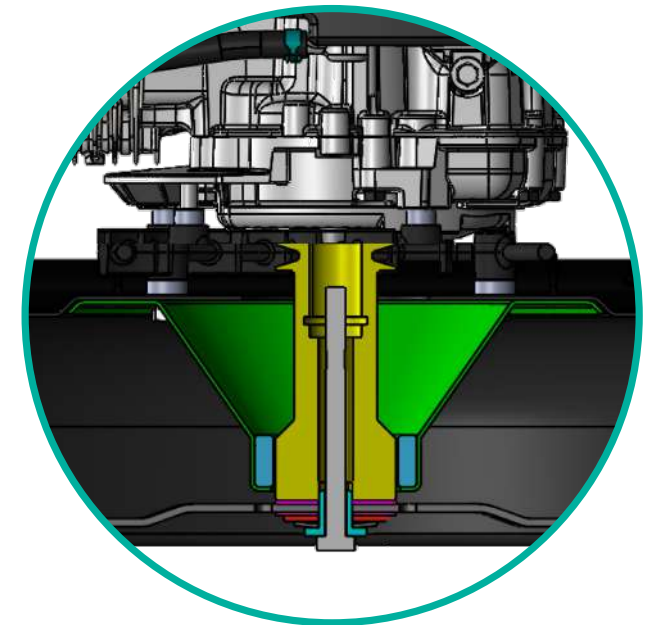

Centralised cut adjustment



The 5500 Mulching model has been designed to meet the requirements of the most demanding users. In fact, it is the only machine on the market equipped with centralised cutting adjustment, by means of a convenient pedal without switching off the engine, positioned at the rear of the mower.

Thanks to this innovative system, cutting adjustment can also be varied while working.

Scarifiers

Breathing fresh air waiting for spring

A beautiful lawn certainly plays an important role in the presentation of a house or a park, it contributes to making a cozy space for children and for all outdoor activities.

Lawn aeration is the best way to invigorate your garden grass. The aerator scarifier is the ideal tool for cleaning the turf and ensuring the health of your lawn, removing harmful felt and thus promoting chlorophyll photosynthesis and deep growth of strong and healthy grass roots.

VIDEOS



Under the microscope

Scarifier

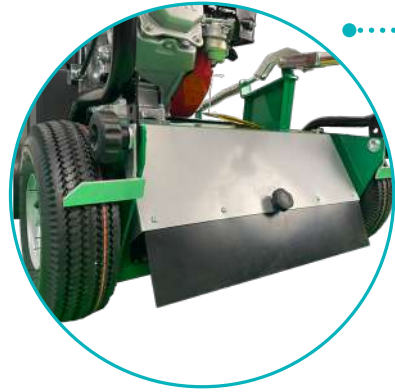

•..... **Scrapers** with adjustable wheels (available for the AC500 model only).

Rotor Rotor with four offset blade sections to optimise machining and minimise engine power absorption, thus ensuring lower consumption.

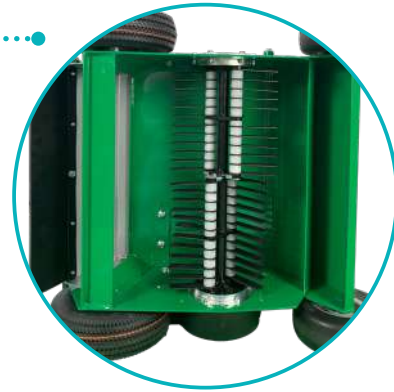

•..... **Front wheel** Metal wheel with solid wheels.

Cutting depth adjustment Dual-function system: quick lift for transport and fine adjustment by turning the knob.

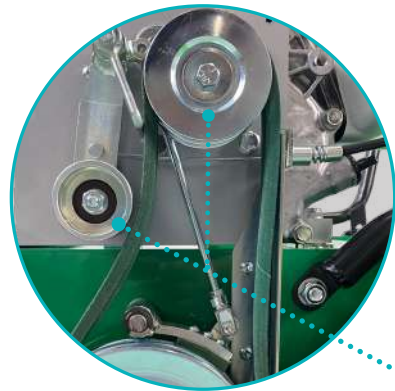

•..... **Belt tension compensator** Safeguards the belt.

Pulley and Working voltager in steel Wear- and heat-resistant with Kevlar strap.

Scarifiers



025911

CODE	MODEL	ENGINE	DECK	N° OF BLADES	WORKING BLADES (cm)	WORKING DEPTH (mm)	WEIGHT (kg)
854000	AC500	HONDA GX160	ACCIAIO	48 MOVABLE	50	25	74



025178 025177

CODE	MODEL	ENGINE	DECK	N° OF BLADES	WORKING BLADES (cm)	WORKING DEPTH (mm)	WEIGHT (kg)
854001	AC400	ACTIVE 212	ALLUMINIO	24 MOVABLE	38	25	41

Optional



Complete fixed blade kit



70 L catcher kit

Hedge trimmers

Green walls...

To care for your hedge, you need a balanced, lightweight and low-vibration machine. You can find all this in our H24 model, configured with two different types of blades, the shortest 600mm and the longest 750mm.

Ideal for all types of hedge meets all the needs of the professional and the demanding private user; ergonomic details have been designed to ensure maximum comfort in any type of use; the adjustable handle, coated with anti-sweat sheath, ensures extreme grip in all positions.

 VIDEOS



Hedge trimmers

Under the microscope

Hedge trimmers SHARK

Battery machines



Revolving handle

Thanks to the swivel handle during vertical cutting, the wrist movement is not stressed and stressed to maintain the blade position.

3 speed

adjustable by a button on the handle.

3 batteries

on the same machine configuration you can use either the cordless battery (2.5 Ah or 5 Ah), or connect the backpack battery (20 Ah).

LED

The LEDs positioned on the handle indicate the selected speed mode; moreover, through different flashes, they signal any anomalies of the machine.



Technical sheet

SHARK

Included in delivery:

- cordless battery 40 V 2.5 Ah
- charger



CODE	MODEL	POWER (w)	BLADE LENGTH (cm)	WEIGHT (kg) without battery
600460	SHARK 60	1200 - brushless	60	3.8
600475	SHARK 75	1200 - brushless	75	4.1

3 batteries model



Cordless battery
40 V 2,5 Ah

CODE: 027601



Cordless battery
40 V 5 Ah

CODE: 027811
available from September 2024



Backpack battery
40 V 20 Ah

CODE: 026250

CODE	VOLTAGE (v)	CAPACITY (Ah)	RANGE*	CHARGING TIME
027601	40	2.5 Ah	40/60 min	1.5 h
027811	40	5 Ah	80/120 min	3 h
026250	40	20 Ah	5 h	6 h

* Autonomy is influenced by the nature of the work required

Hedge trimmers H24



CODE	MODEL	DISPLACEMENT (cm ³)	POWER (cv/kW)	CARBURATOR	Ø CLUTCH (mm)	TANK CAPACITY (L)	WEIGHT (kg)
123TS60	H24 - blade 600 mm	23.0	1.2/0.9	Walbro WYK	54	0.52	5.5
123TS75	H24 - blade 750 mm	23.0	1.2/0.9	Walbro WYK	54	0.52	5.8



Easy Start system
for easy starting.

Revolving handle

Thanks to the revolving system of the handle during vertical cutting, wrist movement is not strained and stressed to maintain the position of the blade.

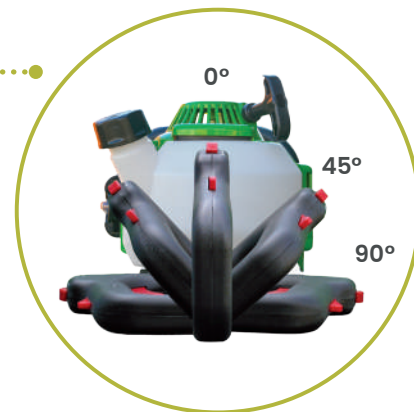

Front discharge

Thanks to the extension coming from the muffler, exhaust gases are projected to the front and thus away from the operator.

M.T.P. series

Strato charged engine
Easy start



M.T.P 1500

CODE	DISPLACEMENT (cm ³)	POWER (cv/kW)	MACHINE LENGTH (mm)	BAR LENGTH (mm)	TANK CAPACITY (L)	WEIGHT (kg)
1252018	25.4	1.7/1.25	2150	480 Ultralight	0.6	5.5



M.T.P ST25 R

CODE	DISPLACEMENT (cm ³)	POWER (cv/kW)	MACHINE LENGTH (mm)	BAR LENGTH (mm)	TANK CAPACITY (L)	WEIGHT (kg)
1252020	25.4	1.7/1.25	2000	254	0.6	5.5

Multigrease spray



High quality, anti-wear product with:
 - Red Spout: conveniently placed in the Multigrease cap. Suitable for directing the product to the desired point, without waste.
 - Grey Nozzle: included in the package, it helps you to conveniently target the grease in the section of the ball greasers.

PACK OF 12 PIECES
Code: **024836**

POWER TRACK

An effective solution to help you save time and effort.

Work effectively saving time and making the least effort, you know, everyone would love it! All this can be part of your daily routine with Power Track Active.

Our crawler minitransporters facilitate your work by making the transport of heavy materials easy and safe, thereby reducing the risk of occupational accidents. Efficient and robust, they are easily maneuverable in any condition of use. The unique track tread of our trolleys ensures incredible traction: on uneven terrain, gravel and even stairs. For all their skills, these minitransporters are excellent allies for all demanding jobs.

 VIDEOS



Power Track

Under the microscope

Power track



Easy-to-operate **controls** offer precision and controllability. **Safety brake** for immediate stops.

Tracks with a wide tread profile ensure perfect grip and stability on all types of terrain.

Robust **frame** with thick steel construction that limits vibration and noise. The position of the engine and transmission facilitates maintenance



Gearbox detail

Gear transmission with 3 forward and 2 reverse gears.



- Galvanised half-shaft sleeves with welded flanges to ensure perfect alignment and long bearing life with or seals to ensure oil seal.
- Oversized parking brake.
- Axle shaft lock on fast shaft to reduce torque and reduce clutch wear.
- Very thick die-cast aluminium crankcase with reinforcements, fully CNC machined.

on 1460-1600

Gear transmission with 2 forward and 1 reverse gears.



- Special, sophisticated cusp couplings facilitate gear engagement.
- Oversized to ensure long service life.
- Half-shaft sleeves with welded flanges to ensure perfect alignment and long bearing life with or seals to ensure oil seal.
- Parking brake.

on 1315-1350-1400

OPTIONAL



Hydraulic tipping kit
Cylinders and Tubes

* A hydraulic control unit kit must be purchased for the hydraulic tipping kit.



Hydraulic Control Unit kit
Cylinders and Tubes



PTO kit
Power take-off



Snow Plough kit
Cylinders and Tubes



Sprayer kit

* For the Sprayer kit you need to buy the PTO Kit.

Easy to operate tool, allows the cleaning of the stable, the bulk of loose material and the removal of snow or inert material. The kit consists of a sturdy steel blade that can be adjusted both vertically and laterally.

The blade can be easily mounted and disassembled. The vertical movement is guaranteed by a hydraulic system with locking valve and quick couplings, while the lateral movement is guaranteed by a practical manual adjustment system. It is also equipped with the distributor's floating position.

DATA SHEET	
BLADE LENGTH	1040 mm
BALDE HEIGHT	495 mm
ANGLE OF OPERATION	+15° / -45°



Ideal for targeted and selective treatments on vegetation and crops between rows even when space is reduced and the soil difficult. A practical valve allows you to precisely adjust the pressure according to the type of use. The large tank guarantees long operating autonomy.

DATA SHEET	
MAX. FLOW RATE	35 litres/min
TANK CAPACITY	200 litres
PUMP	membrane
MINIMUM HEIGHT FROM GROUND	65 mm
MAX PRESSURE	40 bar
POWER TRACK 1460 + KIT	210 kg
MAXIMUM OVERALL DIMENSIONS	670 mm x 2100 mm x 1160 mm (h)
PRESSURE ON GROUND KG/CM2	Unloading: 0.090 Loading: 0.135



Power track series

Power track 1600



40640 800964 800963

CODE	TIPPING	MODEL	ENGINE	DISPLACEMENT (cm³)	POWER (Cv/kW)	WEIGHT (kg)
800950	MANUAL	EXTENDABLE	Mitsubishi GB 181	181	6.3/4.7	245
800951		DUMPER				245
800952	HYDRAULIC	EXTENDABLE				255
800953		DUMPER				255



CODE	TIPPING	MODEL	ENGINE	DISPLACEMENT (cm³)	POWER (Cv/kW)	WEIGHT (kg)
800907	HYDRAULIC	EXTENDABLE	Mitsubishi GB 181	181	6.3/4.7	200
800933		EXTENDABLE + PTO				
800906		DUMPER				
800934		DUMPER + PTO				
800936		SPRAYER				

Power track 1460



40639 800939 800924 800903 800940

CODE	TIPPING	MODEL	ENGINE	DISPLACEMENT (cm³)	POWER (Cv/kW)	WEIGHT (kg)
800900	MANUAL	EXTENDABLE	Mitsubishi GB 181	181	6.3/4.7	190
800931		EXTENDABLE + PTO				
800901		DUMPER				
800932		DUMPER + PTO				
800929		SPRAYER				

Power track 1400



CODE	TIPPING	MODEL	ENGINE	DISPLACEMENT (cm³)	POWER (Cv/kW)	WEIGHT (kg)
800860	MANUAL	EXTENDABLE	HONDA GX160	163	4.8/3.6	175
800865		DUMPER				175
800861	HYDRAULIC	EXTENDABLE				175
800866		DUMPER				175

Power track 1350



CODE	TIPPING	MODEL	ENGINE	DISPLACEMENT (cm³)	POWER (cv/kw)	WEIGHT (kg)
800855	MANUALE	ESTENSIBILE	HONDA GX160	163	4.8/3.6	175
800856			ACTIVE	212	6.0/4.4	

Power track 1315



CODE	TIPPING	MODEL	ENGINE	DISPLACEMENT (cm³)	POWER (cv/kw)	WEIGHT (kg)
800830	MANUAL	EXTENDABLE	HONDA GX160	163	4.8/3.6	170
800831			ACTIVE	212	6.0/4.4	

Traction with pivoting rollers

The obsessive care taken in the construction of the ACTIVE powertracks can be seen in all the components used on the machine, including the double bearings mounted on the traction rollers. The 1350 and 1400 versions are equipped with pivoting rollers which compensate for any imbalance of the machine in the roughest and most inaccessible terrain, thus guaranteeing traction efficiency, maximum stability and, above all, extreme safety even in the most severe working conditions.



Electro Power Track

This power track is suitable for transporting any material in a variety of sectors. To ensure better machine use by workers, it has been designed with the following requirements: fully mechanical traction, acceleration, deceleration and engine revs programmable via a control unit, rubber tracks. It boasts a service life of 1 hour at full load in continuous operation; it requires a recharge of just 8 hours and, of course, emits no exhaust gases and no noise.



1460 Electro Extendable



1460 Electro Dumper

CODE	TIPPING	MODEL	ENGINE	POWER (cv/kw)	GEARBOX	WEIGHT (kg)
800921	MANUAL	EXTENDABLE	Electric D.c.	4.1/3.0	3AV - 3RM	210
800922		DUMPER				210

Flail mowers

Chopping and shredding...

We debunk a myth. Flail mowers are machines used mainly in the agricultural sector, but they are very useful even in smaller areas. These machines grind and exhaust both grass and prunings, branches and small shrubs, thus favoring rapid decomposition and leaving the soil clean for a long time.

Equipped with knives that work simultaneously, the Flail mowers shreds any type of vegetation that meets in its path.

ACTIVE offers different types of Flail mowers depending on the required cutting width, the type of soil to be worked and the engine power.



VIDEOS



Flail mowers

Under the microscope

Flail mowers HD



All Flail mowers Active are equipped with mechanical unlocking of the rear wheels



Tension compensators for automatic belt Working voltage adjustment to prevent belt slippage. This allows greater visual control of register adjustment.

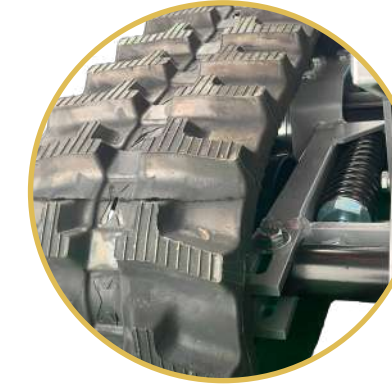

Automatic belt tensioning thanks to the specially designed springs

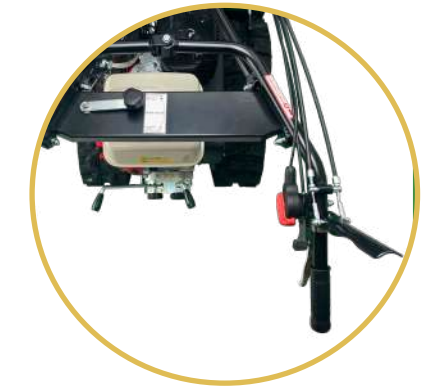

Ergonomic handlebar with 5 vibration dampers, adjustable in height and laterally with one lever

on PRO/HD



Rotor with four offset blade sections to optimise machining and minimise engine power absorption, thus ensuring lower consumption



Front solid rubber wheels fitted with steel rim complete with steering lock

on PRO/HD



Load compensators on the rear axle according to the various gradients ensuring maximum grip in all working conditions

How to choose a flail mowers

When choosing a flail mowers, it is good to make use of the advice of trained and competent sales staff. First of all, the size of the surface to be machined must be taken into account, thus determining the most suitable cutting width and motor power.

Models HD

Flail mowers **equipped with mechanical belt release and lock.** Height and laterally adjustable handlebar with a single control, equipped with 5 vibration-damping bushings.



CODE	MODEL	WORKING WIDTH (cm)	ROTOR FLAILS	ENGINE	POWER (cv/kW)	WEIGHT (kg)
853014	AC 942 HD	87	48	B & S Vanguard 400	14.3/10.5	268
853004				HONDA GX390	11.0/8.2	258
853000	AC 642 HD	60	32	HONDA GX270	8.2/6.0	233

Models PRO

Flail mowers **equipped with mechanical rear wheel release and lock.** Height and laterally adjustable handlebar with a single control, equipped with 5 vibration-damping bushings.



CODE	PRODOTTO	WORKING WIDTH (cm)	FLAGELLI ROTORE	ENGINE	POWER (cv/kW)	WEIGHT (kg)
852004	AC 942 PRO	87	48	HONDA GX390	11.0/8.2	213
852002	AC 842 PRO	75	40	HONDA GX390	11.0/8.2	198

Models 621 - 642

Flail mowers **equipped with mechanical release.** Height and laterally adjustable handlebar.



CODE	MODEL	WORKING WIDTH (cm)	ROTOR FLAILS	ENGINE	POWER (cv/kW)	Ø FRONT WHEELS	WEIGHT (kg)
851002	AC 642	60	32	HONDA GX270	8.2/6.0	16x6.5 8	168
851000	AC 621	60	32	HONDA GX200	5.6/4.1	13x5.0 6	138

Sod cutters

Rolling lawns: easy soil preparation

Simplicity, ease and convenience, the three main features that our Sod Cutters will give you when removing and replacing the deteriorated turf.

The care and maintenance of green areas has never been so easy and effective.



VIDEOS



Sod
cutters

Under the microscope

Sod cutter



Anti-vibration handle thanks to four rubber bushings that reduce annoying vibrations.



Made in Italy aluminium gearbox with two forward gears, extremely resistant to corrosion and stress.



Incredibly durable blade thanks to heat treatment and steel quality.



Sod cutter 2WD Rear-drive

CODE	MODEL	ENGINE	POWER (cv/kw)	WORKING WIDTH (mm)	WORKING DEEP (mm)	WEIGHT (kg)
855004	AC 300 2WD	HONDA GX200	5.5/4.1	300	35	79
855006	AC 390 2WD	HONDA GX200	5.5/4.1	390	35	80

Sod cutter 4WD

Traction 4WD

Double the grip and traction of the wheels during the working phase



CODE	MODEL	ENGINE	POWER (cv/kw)	WORKING WIDTH (mm)	WORKING DEEP (mm)	WEIGHT (kg)
855005	AC 300 4WD	HONDA GX200	5.5/4.1	30	35	79
855007	AC 390 4WD	HONDA GX200	5.5/4.1	39		80

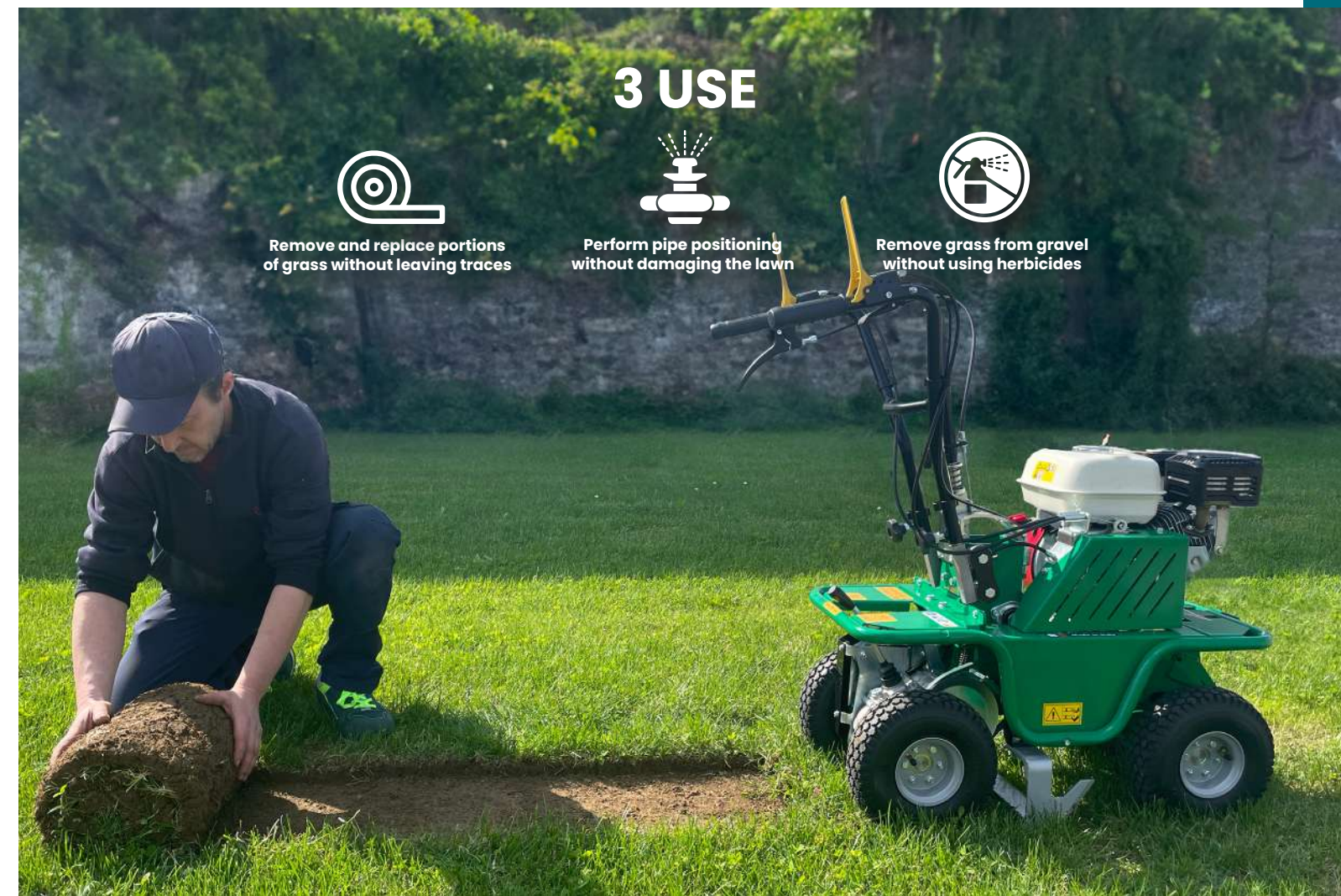

3 USE



Remove and replace portions of grass without leaving traces



Perform pipe positioning without damaging the lawn



Remove grass from gravel without using herbicides

Augers

The power to drill holes for platforms, fences, planting trees and more...

The augers designed by Active are able to perform continuous and heavy machining.

A disadvantage of these machines is the tip that very often tends to get stuck in the ground.

The augers Active do not present this annoying problem because, thanks to the presence of the gearbox locking device, it is possible to extract the drill simply by rotating the drill counter-clockwise with the engine off.

VIDEOS



Under the microscope

Augers



Engine with reinforced crankcase, specially designed to tackle the toughest jobs

Reducer

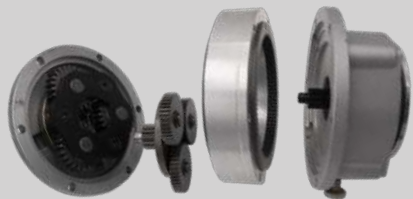

Reducer locking device which allows the tip to be easily extracted from the ground if it becomes jammed



The T152 and T143 models feature a **anti-rotation safety frame** that allows the auger to be used by a single operator

The old shovel? It's the right time to use our augers

Our augers are characterized by high resistance to stress in the most extreme conditions and in all working positions and are ideal for drilling for plants and vines, road lighting works, supports for greenhouses and palisades.

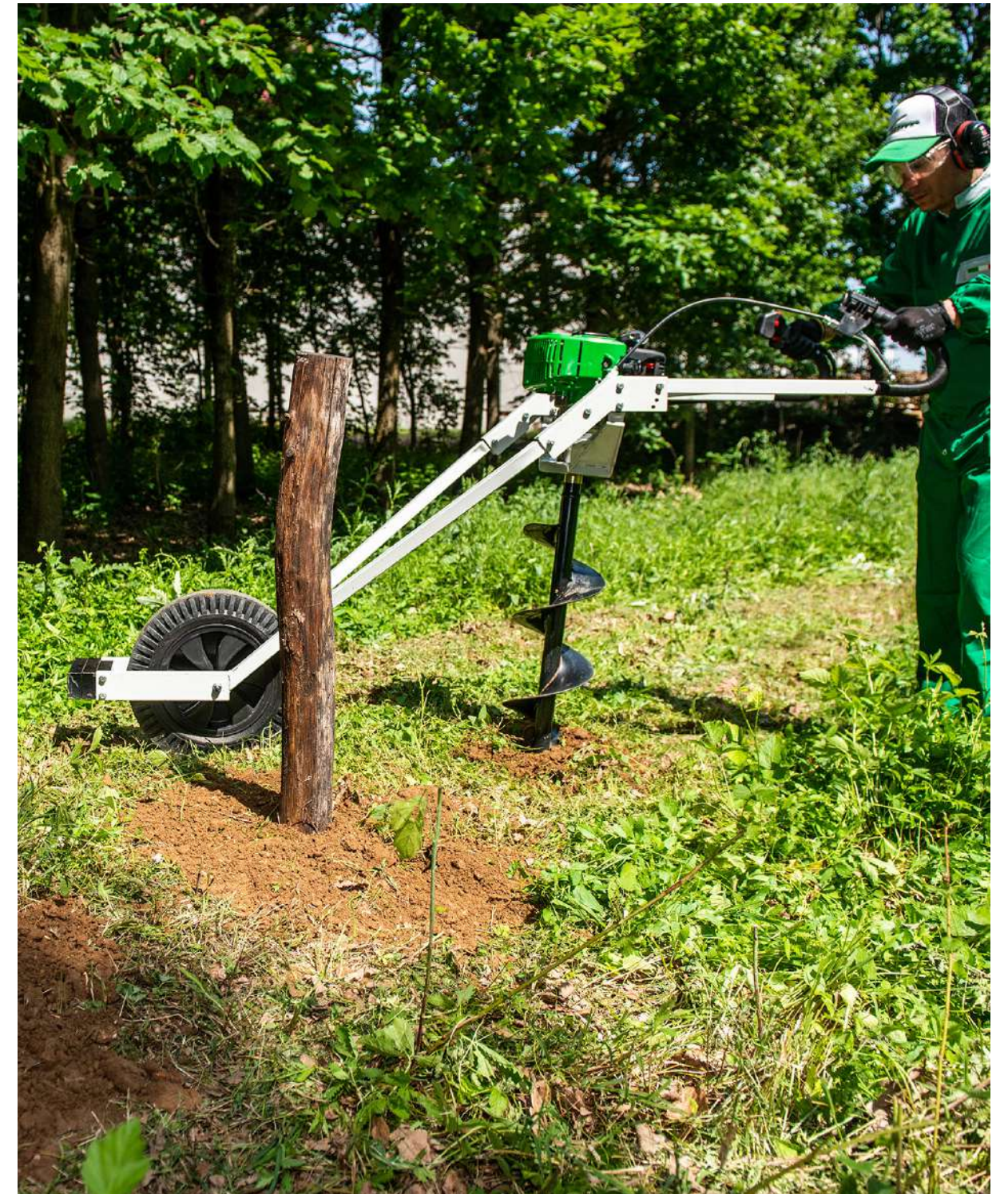



T 152

Professional model T 152 with anti-rotation weighted wheel ideal for drilling in series.

Moving speed means time saving, from this concept ACTIVE has developed T 152. Ideal for work on large spaces, such as the planting of rows of plants or in construction, it has a frame that serves both as a stabilizer against vibration and anti-rotation system. Safe and efficient, it is designed to drill always in a perfectly vertical position and requires only one operator for both work and transport, ensuring significant energy savings.



TDU 155

Professional model with double handle and large displacement TDU 155 is ideal for drilling in confined spaces

All the reliability, quality and professionalism ACTIVE to offer you a safe, lightweight and high performance tool. Designed to deal with the heaviest perforations and on the toughest terrain, TDU 155 is equipped with adjustable handles and can be used by one or two people by enlarging the handles.

The anti-vibration frame also ensures a comfortable and fatigue-free work, which allows you to face the most demanding operations.

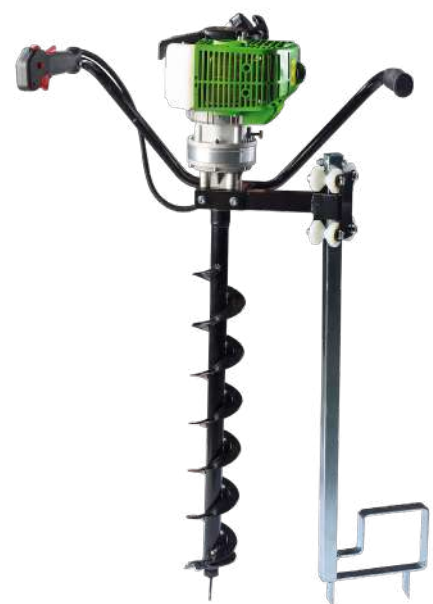

T 143

Medium displacement professional model: T 143 is lightweight, versatile, easy to transport, it is equipped with a patented anti-rotation system that allows only one person to work safely.

Designed by ACTIVE for drilling in every sector, from agriculture to construction, T143 is now the only drill on the market to be equipped with an anti-rotation safety system. The motor controls, assembled in one hand, and the anti-vibration frame make it the ideal solution for individual work. This allows you to work comfortably, safely and not tiring even for prolonged periods.

CODE	MODEL	DISPLACEMENT (cm ³)	POWER (Cv/kw)	REDUCTION RATIO	MAX. SPEED ROTATION	TANK CAPACITY (L)	WEIGHT WITHOUT BIT (Kg)
1600001	T152	51.7	3.0/2.2	50:1	170 rpm	1.1	43
1600007	TDU 155	51.7	3.0/2.2	50:1	170 rpm	1.1	15
1600002	T143	42.7	2.6/1.9	50:1	150 rpm	1.1	15



Extension

The ACTIVE coupling device enables vary the depth of drilling in a few seconds. Total extension length 270 mm (90 mm x 3 positions). Possibility to add more extensions.

Code: 020955

Drills and blades

Robust single-principle drill bits with a single cutting tip made of special steel for high performance and high wear resistance. Designed to withstand the high torques of ACTIVE augers, the drill bits are equipped with a heavy-gauge helix for decisive, vibration-free and long-lasting drilling.



Complete bits

DRILLS (mm)	CODE	LENGHT. (mm)	WEIGHT (kg)
Ø 80	020689	730	3.0
Ø 100	020690	730	3.7
Ø 150	020691	730	6
Ø 200	020692	730	7.4
Ø 250	020693	730	8
Ø 300	020694	730	8.7
Tapered from Ø 300 to Ø 400	023363	730	6.8

Replecement for blades

BLADES (mm)	CODE
Ø 80	021071
Ø 100	021071
Ø 150	021072
Ø 200	021073
Ø 250	021074
Ø 300	021075
Tapered from Ø 300/400	021075
puntale	021042

Shakers & Harvester

Olives, walnuts and almonds: maximum yield while cutting costs...

Shakers & Harvesters Active are the perfect allies for every user: robust, technologically advanced, reliable and able to guarantee high performance. Attentive to the user's comfort and the protection of the plant, they allow to obtain a much higher yield than that of manual harvesting.

We have at your disposal a wide range of Shakers & Harvesters divided according to the type of power supply of the machine: 12V, 40V and 48V external power; with 40V lithium backpack battery; with endothermic motor.

Regardless of the power supply, all Active models are designed to the highest quality standards.

Nowadays, the most requested typology is that of the battery powered electric barkers because, besides ensuring an excellent yield, they are silent and light to maneuver.

Shakers & Harvesters

VIDEOS



Under the microscope

Shakers OLIVATOR® M series



Patented handle with vibration-dampening function for maximum comfort and with bar turning control to prevent the branch hook from slipping out when the machine is running.



Clutch bell without welds so that the bell does not detach from its hub.



Helical reducer in oil bath. Quiet and reliable, it is designed to transmit all the power of the engine to the hook without dispersion for the benefit of efficiency.



Professional three-sector clutch, oversized 78mm with progressive engagement, with pads made of special material.



Handle

Oscillating handle for total machine control and reduced vibrations. Made of special plastic and sheathed in sweat-proof rubber to increase grip. The integrated throttle control with the locking system allows control at every stage.



Shakers OLIVATOR® M series



M70 e M60

CODE	MODEL	DISPLACEMENT (cm³)	Ø SHAFT (mm)	POWER (cv/kw)	WEIGHT (kg)
1600801	M70 - reinforced shaft 2 m	63.0	30	4.5/3.3	14.5
1600805	M70 - reinforced shaft 4 m	63.0	30	4.5/3.3	14.5
1600702	M60 - shaft 2 m	51.7	30	3.0/2.2	14
1600703	M60 - telescopic shaft	51.7	30	3.0/2.2	14

M50



CODE	MODEL	DISPLACEMENT (cm³)	Ø SHAFT (mm)	POWER (cv/kw)	WEIGHT (kg)
1600753	M50 - reinforced shaft 2 m	51.7	26	3.0/2.2	10.5
1600754	M50 - telescopic shaft	51.7	26	3.0/2.2	10.5

Weight refers to the machine body without shaft

Under the microscope

Electric harvesters

OLIVATOR® E series



New anti-vibration head

Completely redesigned to allow prolonged, effortless and vibration-free use.



Double bearing

The special technical solution adopted in the head construction, with double bearings on the tine holders, improves the stability of the harvester and prolongs its longevity.



Ergonomic handle

Robust in special plastic throughout: comfortable and ergonomic to use.

Energy, always under control!

Thanks to the system of dynamic indicators of battery status, you will no longer have to fear being without. The battery status is monitored using NFC technology.

CODE	VOLTAGE (V)	CAPACITY (Ah)	RANGE*	CHARGING TIME	WEIGHT (kg)
026250	40	20 Ah	5 h	6 h	5,4 with harness

* Autonomy is influenced by the nature of the work required



Electric harvesters

OLIVATOR® E series

L
Length: from 2100 to 3100 mm

XL
Length: from 2400 to 3700 mm

Olivator E-5000

Power 600W

(40V Brushless engine)



CODE	MODEL	PRODUCTIVITY (kg/h)	CABLE	POWER SUPPLY	WEIGHT (kg)
600994	E-5000 BP L	100/140	1.8 m with connector	Battery 800w e 20Ah backpack	2,5
600995	E-5000 BP XL				2,8
600984	E-5000 L	100/140	20 m with clamp and connectors	Electric 12 V + power supply unit	2,5
600985	E-5000 XL				2,8

Olivator E-4800HD

Power 400W

(48V engine)



CODE	MODEL	PRODUCTIVITY (kg/h)	CABLE	POWER SUPPLY	WEIGHT (kg)
600980HD	E-4800HD L	90/120	20 m with clamp and connectors	Electric 12 V + power supply unit	2,4
600981HD	E-4800HD XL				2,7

Olivator E-1200

Power 300W

(12V engine)



CODE	MODEL	PRODUCTIVITY (kg/h)	CABLE	POWER SUPPLY	WEIGHT (kg)
600970	E-1200 L	80/110	10 m with clamp and connectors	Electric 12 V	2,5
600971	E-1200 XL				2,8

Chainsaws

From small twigs to big logs...

For the demanding professional or hobbyist, for forestry work, felling or simple care of green areas, with the wide range of Chainsaws Active you will be able to cope with every situation with the most suitable tool.

Constant in all models are quality, safety, speed and comfort guaranteed by Active technology.

VIDEOS



Under the microscope

Chainsaws



Chilled roll cylinder. Offering greater structural stability and better cooling.



Piston with two piston rings made of special cast iron for durability



All-steel case-hardened oil pump for durability

on 51.51 56.56 62.62

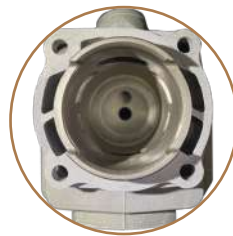

Fully machined combustion chamber dome for better efficiency, lower emissions



Active's technology and experience have led to the design of an innovative specific engine capable of tackling even the heaviest duty and most continuous work with ease. Equipped with a high and constant torque at different rpm, it is suitable for a great flexibility of use.

Vegetable Oil (100%) for bars and chains

This oil, obtained exclusively from virgin oils, guarantees total biodegradability. The added additives guarantee high anti-wear and maximum adhesiveness, optimally protecting the oil pump while at the same time providing an effective antioxidant and anti-corrosive action.

ACTIVE oil is also extremely heat-resistant. Thanks to its excellent viscosity index and low polymerisation index, ACTIVE oil is suitable for professional use, continuous operation and severe operating conditions.



Professional



62.62

CODE	MODEL	DISPLACEMENT (cm³)	POWER (cv/kW)	MIX TANK (L)	OIL TANK (L)	BAR CHAIN	WEIGHT* (kg)
1620065	62.62	62.0	4.6/3.4	0.65	0.34	.325" x 1.5/40 cm	5.6
1620062						.325" x 1.5/45 cm	
1620063						3/8" x 1.5/50 cm	

56.56

CODE	MODEL	DISPLACEMENT (cm³)	POWER (cv/kW)	MIX TANK (L)	OIL TANK (L)	BAR CHAIN	WEIGHT* (kg)
1560057	56.56	56.0	4.1/3.0	0.65	0.34	.325" x 1.5/40 cm	5.6
1560058						3/8" x 1.5/45 cm	
1560059						3/8" x 1.5/50 cm	

51.51

CODE	MODEL	DISPLACEMENT (cm³)	POWER (cv/kW)	MIX TANK (L)	OIL TANK (L)	BAR CHAIN	WEIGHT* (kg)
1510051	51.51	51.0	3.8/2.7	0.65	0.34	.325" x 1.3/40 cm	5.6
1510053						.325" x 1.5/40 cm	
1510052						.325" x 1.5/45 cm	
1510054						3/8" x 1.5/45 cm	
1510055						3/8" x 1.5/50 cm	

EASY START

Start up and begin working. With your left hand you grasp the bow handle, with your right the ignition knob, tension the starter rope and with a quick, smooth movement pull the rope out until you feel the preload spring engage.

The automatic control will give the engine a strong enough rotation to start it.



A new technology

For the most manoeuvrable and pruning chainsaws, suitable for cutting large logs, we at Active have applied the most advanced technological features to the ergonomic design:

- The EasyStart system
- Reduced consumption and pollutant emissions;
- Special ceramic spark plug that increases engine speed;
- Electronic ignition with variable advance (resulting in immediate start-up without recoil even after periods of extreme work).

40.40



39.39



31.31



28.28



40.40

CODE	MODEL	DISPLACEMENT (cm³)	POWER (cv/kW)	MIX TANK (L)	OIL TANK (L)	BAR CHAIN	WEIGHT* (kg)
14HV836	40.40	38.0	2.5/1.8	0.35	0.22	3/8" x 1.3/35 cm PRO91	3.8

39.39

139H042	39.39	38.0	2.5/1.8	0.35	0.22	1/4" x 1.3/25 cm carving	3.5
139H043						3/8" x 1.3/30 cm PRO91	
139H044						3/8" x 1.3/35 cm PRO91	

31.31

310031	31.31	30.1	1.4/1.03	0.24	0.18	3/8" x 1.3/30	3.46
--------	-------	------	----------	------	------	---------------	------

28.28

280028	28.28	30.1	1.4/1.03	0.24	0.18	3/8" x 1.3/25 cm	3.0
280038						3/8" x 1.3/30 cm	
023879						(Dx)Kit carving 1/4	
024576						(Sx)Kit carving 1/4	

*without bar and chain

PRUNERS AND TYING MACHINES

Simple cutting for olive groves, vineyards and fruit trees.

Active electronic pruners are designed and manufactured to facilitate the pruning of vineyards, olive groves and fruit trees. Powerful and precise, they are characterized by a remarkable cutting speed and are able to cut branches with a diameter from 1.5 cm up to 4 cm.

During pruning you can consult the functional parameters of the Pruners both on the integrated LCD display and on the external battery, for the Tigercut 40 model.

The latter can be comfortably attached to the belt of the work uniform, so as to have a quick and complete view of the state of the electronic scissors: current battery charge and number of cuts performed, partial and total.

 VIDEOS



Pruners and tying machines

Electronic chain pruner

Dragoncut

- 1 Enhanced BRUSHLESS electronic card and motor
- 2 Removable side door for easy cleaning of the electric motor
- 3 Automatic oil pump
- 4 Increased oil cap to facilitate filling of the oil tank
- 5 Hole for lubricating conical torque (under the body)
- 6 Easy chain replacement/maintenance without keys
- 7 Handle designed for a smaller footprint

DRAGONCUT KIT

- Tool kit
- 2 Batteries
- 3 way battery charger
- Sheath
- Chain file



DRAGONCUT

Code: 600815

Power supply: **electric**
Voltage: **14.4 V**
Weight and length: **1.01 Kg - 41.5 cm**
Battery weight: **0.23 Kg**
Charger: **100-240 V AC 50/60 HZ 0.5 A**
Charging time: **1.5 - 2 hours**
Motor power: **500 Watt**

Battery: **2.5 Ah - 36 Wh (x2)**
Chain speed: **8.5 m/s**
Bar length: **4" - 10 cm**
Chain: **1/4" - 34 links**
Lubrication: **Automatic Lubrication**
(after filling the tank)
Grease sprocket: **manual**



Electronic pruners

Tigercut

- 1 The handle is in soft-touch**, It was designed specifically to make the usage experience phenomenal.
- 2 The coating is made of ultra resistant technopolymer** to withstand accidental impacts and last over time.
- 3 the backlit LCD display** will always tell you in which condition your TIGERCUT is. Number of cuts, partials, totals, battery level and diagnosis of possible failures.
- 4 Powerful motor, silent and without any vibration.** This is **brushless technology**.

The blades made of high strength alloy and hardened steel do not stop at any obstacle! Progressive closing will allow you to control the cut more accurately, and you can select smaller openings to speed up cutting operations.

TIGERCUT KIT

Supplied with all models TIGERCUT 25 - 32 - 35 a resistant case complete with:

- Tool kit
- 2 Batteries
- 3 way battery charger
- Whetstone
- Sheath ACTIVE



TIGERCUT 25

Code: 600825



Max. working voltage: 16.8V
Battery capacity: 2Ah
Max. cutting width: 25mm
Medium cutting width: 15mm
Progressive cut: yes
Max. power: 500W
Weight : 940g with battery
Tempo di ricarica: 1 - 1.5h
Durata battery: 3-4h /Battery*
Built-in LCD display
Brushless motor

Code: 600832

Max. working voltage: 16.8V
Battery capacity: 2,5Ah
Max. cutting width: 32mm
Medium cutting width: 15mm
Progressive cut: yes
Max. power: 500W
Weight : 950g with battery
Tempo di ricarica: 1 - 1.5h
Durata battery: 3-4h /Battery*
Built-in LCD display
Brushless motor

TIGERCUT 32



TIGERCUT 35

Code: 600835



Max. working voltage: 25,2 V
Battery capacity: 2.5Ah
Max. cutting width: 35mm
Medium cutting width: 20mm
Progressive cut: yes
Max. power: 680W
Weight : 1240g with battery
Tempo di ricarica: 2- 2.5h
Durata battery: 4-6h /Battery*
Built-in LCD display
Brushless motor

TIGERCUT KIT

Supplied with all models TIGERCUT 25 - 32 - 35 a resistant case complete with:

- Tool kit
- 2 Batteries
- 3 way battery charger
- Whetstone
- Sheath ACTIVE



Extension



TIGERCUT 35

Shaft Length(mm): 1550/2200

Code: 025968



TIGERCUT 25/32

WIRELESS CONNECTION
Shaft Length(mm): 1550/2200
Code: 025967

TIGERCUT 40

Code: 600840* | 600844**

The mechanical part of the blade drive is oversized, to ensure a long life in heavy cutting conditions.

Even the most difficult shrub can be pruned easily thanks to the large opening of the steel blades up to 40mm. The battery and its hook allow you to work with great autonomy and comfort. The ergonomic handle and progressive cutting will make cutting operations easy, fast and comfortable.

Working voltage: 43.2V
Battery capacity: 2.5Ah*/4Ah**
Max. cutting width: 40mm
Medium cutting width: 25mm
Progressive cut: Si
Max. power: 1200W
Weight : 860g with battery
Charging time: 2 - 2.5h
Battery duration: 5-7h* /7-9**
Built-in LCD display
Brushless motor



TIGERCUT KIT

- Tool kit
- Battery
- Battery charger
- Connection cable scissors-battery
- Sheath ACTIVE
- Backpack strap for battery pack
- Whetstone blade



MULTIGREASE SPRAY

Ideal for all the pruners



High quality, anti-wear product with:
Red spout: conveniently stored in the Multigrease cap. Suitable for directing the product to the desired point, without waste.
Grey Nozzle: included in the package, it helps you to conveniently target the grease in the section of the ball greasers. The spray grease will allow you to properly lubricate the Pruners; the recommended lubrication is at regular intervals after each use and maximum every 10 hours.



WRAP-X

Code: 600820

Max. working voltage: 16.8V
Battery capacity: 2Ah
Max. tying capacity: 25mm
Tying modes: 4
Tying modes: 50W
Weight : 1180g with battery
Charging time: 1 - 1.5h
Battery duration: 6-8h*
Built-in LCD display
Brushless motor



KIT WRAP-X

- Tool kit
- 2 Batteries
- 2 way battery charger
- 2 Polymer BIO reels
- Briefcase

WRAP-X

The tying revolution is here.

We have designed the new ACTIVE Wrap-X tying machine. The new brushless motor helps the Wrap-X tying machine achieve incredible performance without any vibration, friction or loss of power. Three types of cord are available so you can find the one best suited to your needs. The revolutionary new display will show you the essential information: The number of ties made, the current charge level and much more, all at your fingertips. The two batteries included in the package have been specially redesigned to optimise power distribution within the digital control board.

Polypropylene*
ensures long-lasting tying



BIO* polymer
degradability
9/10 months

Paper* excellent for
organic cultivation,
degrades in 6/8 months

*Available in 90m and 500m formats

**500 m reel
dispenser:**



Code: 25634

Tillers

Power, reliability, ease of use and transport. All the features you will find in the ACTIVE tillers, suitable for small-scale trimming or cultivating medium-sized vegetable gardens. Equipped with quiet 4-stroke engines, they are powerful and very easy to handle.



VIDEOS



Tillers

AC1000

Code: 800730



Engine: Active 4T
Displacement: 212 cc
Power: 4.4 kW
Air filter: oil bath
Gear: 2 forward + 1 reverse
Working width: 100 cm
Handlebar: height adjustable
Front wheel: yes
Tractor wheels for transport: yes
Transmission: gears with oil bath clutch
Weight : 79 Kg
Optional: movable furrower

Code: 800725

AC900

Engine: Active 4T
Displacement: 196 cc
Power: 4.1 kW
Air filter: oil bath
Gear: 2 forward + 1 reverse
Working width: 60-90 cm
Handlebar: height adjustable, laterally adjustable
Front wheel: yes
Tractor wheels for transport: yes
Transmission: double belt and gears
Weight : 85 Kg
Optional: movable furrower



Code: 800715

AC600



Engine: Active 4T
Displacement: 196 cc
Power: 4.1 kW
Air filter: oil bath
Gear: 1 forward + 1 reverse
Working width: 60-90 cm
Handlebar: height adjustable, laterally adjustable
Front wheel: yes
Tractor wheels for transport: no
Transmission: belt
Weight : 69 Kg
Optional: -

Optional



Movable Furrower

Can only be used with models AC900 e AC1000

Included



Tractor wheels

Can only be used with models AC 900 e AC1000



Generators AVR and Inverters

An energy source always available wherever you want; the range of Active Generators with AVR system (electronic voltage regulator) protects all connected electronic devices. Built-in voltmeter, reinforced frame and fuel tank increased for long uses.

The new Active Generators are robust, reliable, powerful and easy to carry, thanks to the trolley kit always included. Our models adapt to your needs thanks to the wide choice of power, from 2 to 8.5 Kw also with electric starter.

Unlike AVR Generators, inverters generate completely stabilized voltage, varying the number of engine revolutions as a function of the applied load, resulting in significant fuel savings and noise reduction.

Generators



Generators AVR

Our Generators guarantee long autonomy even at maximum power, thanks to the efficient engines and the large petrol tank. All equipped with trolley kit, they are easy to carry. With tear-off and electric starting, they are easy to set in motion for any user. The wide range consists of single-phase models for domestic use or three-phase for civil use.

MONOPHASE 230V

Engine model: ACTIVE
Type of generator: AVR
Fuel: green petrol

Working voltage: 230 V
Frequency: 50 Hz

Uscita DC: 12 V
Trolley kit: included



AG-2500

Code: 800645

Displacement: 212 cc
Tank capacity: 15 Lt
Starting type: recoil starter
Prese: 2 x SHUCO 230V 16 A
Rated power: 2.0 kW
Max. power: 2.2 kW
Dimension: 600x455x460 mm
Weight: 43,5 Kg

AG-3800

Code: 800655

Displacement: 223 cc
Tank capacity: 15 Lt
Starting type: recoil starter
Prese: 2 x SHUCO 230V 16 A
Rated power: 3.0 kW
Max. power: 3.1 kW
Dimension: 600x455x460 mm
Weight: 45 Kg

MONOPHASE 230V THREEPHASE 400 V

Same power guaranteed in single-phase and three-phase

Engine model: ACTIVE
Type of generator: AVR
Fuel: green petrol

Working voltage: 230 V / 400 V
Frequency: 50 Hz

Uscita DC: 12 V
Trolley kit: included



AG-7500 ET

Code: 800681

Displacement: 420 cc
Tank capacity: 25 Lt
Starting type: recoil starter/electric
Prese: SHUKO 1x 16A
Monophase 1x 32 A 230 V
Threephase 1x 16 A 400 V
Rated power: 6.0 kW
Max. power: 6.5 kW
Dimension: 700x600x580 mm
Weight: 95 Kg

AG-9500 ET

Code: 800690

Displacement: 458 cc
Tank capacity: 25 Lt
Starting type: recoil starter/electric
Prese: SHUKO 1x 16A
Monophase 1x 32 A 230 V
Threephase 1x 16 A 400 V
Rated power: 8.0 kW
Max. power: 8.5 kW
Dimension: 700x600x580 mm
Weight: 102 Kg

Inverters

ACTIVE AGI 2100 and 3500 inverters current generators emit totally clean energy. Perfect for home use, ideal for any type of electronic equipment sensitive to power surges. They are easy and light to carry thanks to the top handle and the 4 wheels integrated in the sturdy frame.

Both have an efficient 4tempi motor with integrated oil alert device. In the model AGI-3500 in addition to the classic handle for starting, there is the' electric start to simplify and facilitate further ignition.

Thanks to the technological system that connects electronic board and carburetor, the engine accelerates only and exclusively when the load applied to the generator requires it. This thus ensures a significant reduction in fuel consumption at low load levels, thereby increasing the overall efficiency of the generator.



AGI-2100

Code: 800625

Engine model: ACTIVE
Type of generator: Inverter
Displacement: 79 cc
Autonomy ½ load: 6,3 h
Working voltage: 230 V
Rated power: 1,8 kW
Max. power: 2,3 kW

Frequency: 50 Hz
Working voltage DC: 12 V
DC current: 8,3 A
Tank capacity: 4 Lt
Starting type: recoil starter
Dimension: 499x285x455
Weight: 21 Kg

AGI-3500

Code: 800635

Engine model: ACTIVE
Type of generator: Inverter
Displacement: 212 cc
Autonomy ½ load: 10 h
Working voltage: 230 V
Rated power: 3,5 kW
Max. power: 4,5 kW

Frequency: 50 Hz
Working voltage DC: 12 V
DC current: 8,3 A
Tank capacity: 10 Lt
Starting type: recoil starter/electric
Dimension: 578x440x510
Weight: 45 Kg



Engines

The engine: the heart of your machine

Powerful, reliable, durable. ACTIVE offers a range of 4-stroke petrol engines, selected according to the type of machine and the work it has to do. Always oversized to offer maximum performance while maintaining low fuel consumption when the operator does not need high power.

All STAGE V, both vertical shaft and horizontal shaft.

Engines

VERTICAL SHAFT 22X60 mm



Model: A140
Displacement: 139 cc
Max. power:
2.4 Kw / 3600 rpm
Max. torque:
7.5 Nm / 2500 rpm
Code:
051564



Model: A166
Displacement: 166 cc
Max. power:
2.9 Kw / 3600 rpm
Max. torque:
9.5 Nm / 2500 rpm
Code:
051565



Model: A200
Displacement: 196 cc
Max. power:
4.0 Kw / 3600 rpm
Max. torque:
12 Nm / 2500 rpm
Code:
051567

HORIZONTAL SHAFT 3/4"



Model: A212
Displacement: 212 cc
Max. power:
4.4 Kw / 3600 rpm
Max. torque:
12 Nm / 2500 rpm
Code:
042044

Engine



Active s.r.l.

Via Delmoncello, 12 - Industrial area 26037 San Giovanni in Croce
Cremona - ITALY | Tel. +39 0375 91742

For orders: ordini@active-srl.com | Export: export@active-srl.com

www.active-srl.com